

APPLICATION:

PRODUCT NAME:
 SINGLE DECK DUAL CONTROL VALVE

JOB NAME:

SPECIAL CONFIGURATION
 CHECK BASE MODEL AND OPTIONS

QUANTITY:

ITEM NO.

MODEL:
 13064

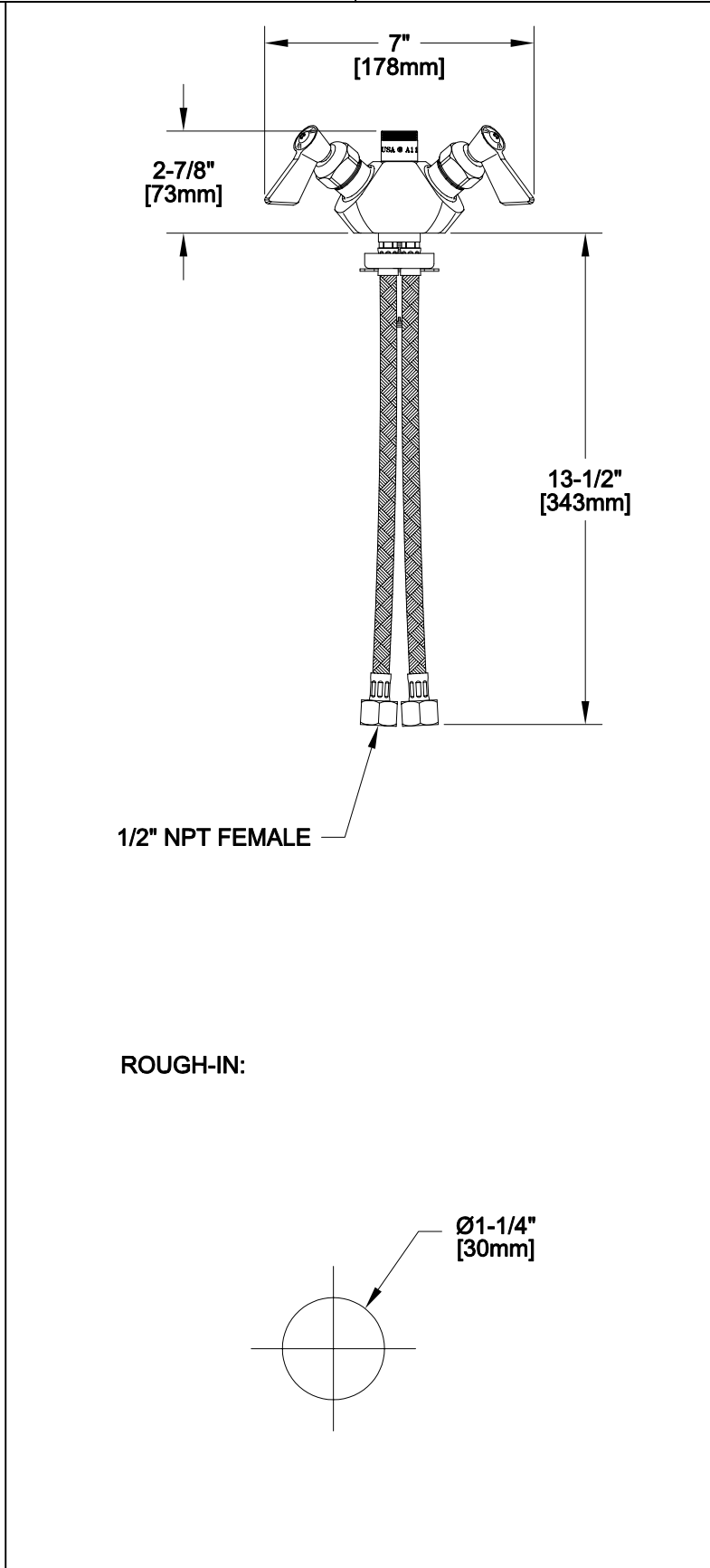

OPTIONS OR MODIFICATIONS:
 SUPPLY LINES (24" OR 36") CIRCLE LENGTH
 HANDLES (CROSS OR WRIST) CIRCLE STYLE
 VANDAL RESISTANT KIT
 OTHER _____

FEATURES

CONTROL VALVE

- * SWIVEL OUTLET
- * HOT SIDE STEM - RIGHT HAND
- * COLD SIDE STEM - LEFT HAND
- * SWIVELLING SEAT DISKS
- * STAINLESS STEEL SEATS
- * STAINLESS STEEL SEAT SCREWS
- * STAINLESS STEEL HANDLE SCREWS
- * FLEXIBLE INLET HOSES

SYSTEM LIMITS

- * TEMP: 40°F MIN. TO 140°F MAX.
- * PRESSURE: 200 PSI MAX. STATIC

SHIPPING WEIGHT

- * 5.0 LBS

FISHER
 FISHER MANUFACTURING COMPANY
 TOLL FREE: 800-421-6162 - FAX: 800-832-8238
 information@fisher-mfg.com - www.fisher-mfg.com